

Lesson 11 – Answers

Q1 Why is feedback necessary in an oscillator?

The oscillator relies on feedback to keep the oscillator in frequency and phase.

Q2 What are the parameters that need to be controlled in an oscillator to maintain its stability?

Temperature Change

Temperature changes can alter the parameters of crystals, resistors, capacitors and inductors.

A Temperature Compensated Crystal Oscillator (TCXO) provides a more precise and stable output. An Oven-Controlled crystal oscillator (OCXO) keeps crystals at a consistent elevated temperature.

Mechanical Vibrations

External vibrations can cause short-term phase fluctuations in the output signal, known as phase noise. The ideal oscillator should have a combination of mechanical isolation and electrical compensation to reduce phase noise.

Power Supply

A regulated and well filtered power supply is essential for a stable oscillator.

Control Parasitic Oscillations

Parasitic oscillation is undesirable feedback in the oscillator and can be caused by feedback in the oscillator amplifier. An example of parasitic oscillations is if a mic is held too close to the speaker and the amplifier goes into uncontrolled oscillation.

Q3 What is a BFO?

Beat frequency oscillator. A beat frequency oscillator (BFO) is a dedicated oscillator used to create an audio frequency signal from Morse code radiotelegraphy (CW) transmissions.

Q4 What is a VCO?

Voltage controlled oscillator. A VCO is an oscillator whose output frequency is controlled by an input voltage.

Q5 What is a PLL?

A phase-locked loop compares the phase of a reference oscillator to the phase of an adjustable oscillator.

Q6 Draw the block diagram of a PLL and name the parts.

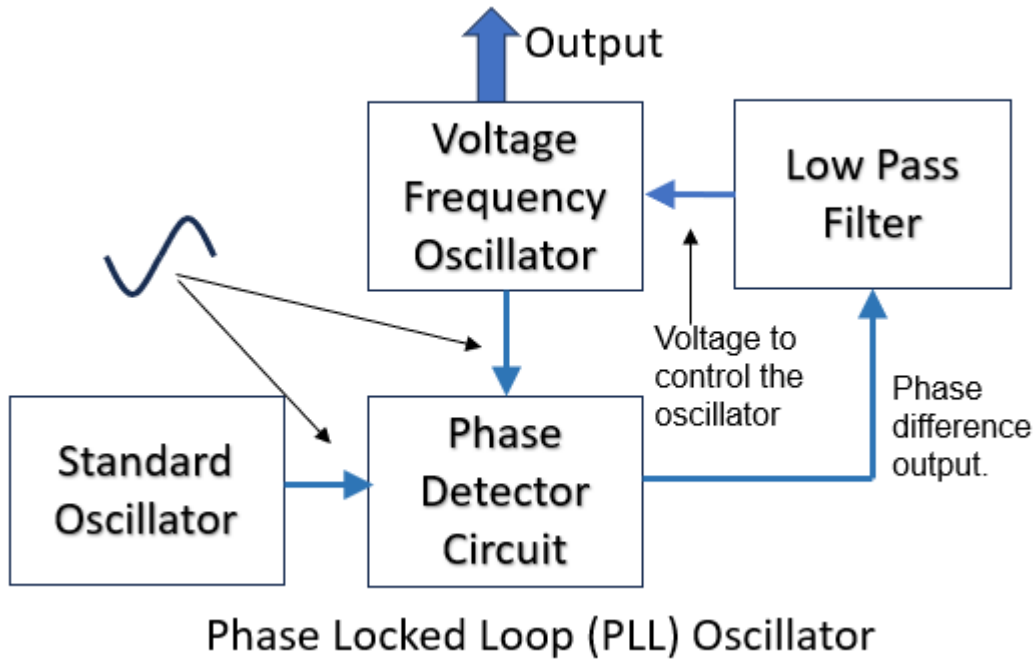

Q7 What was the first oscillator in use and why was it called a tickler oscillator?

The Armstrong oscillator is an oscillator circuit which uses an inductor and capacitor to generate oscillation and is the earliest oscillator circuit. This oscillator was used in the first vacuum tube radio transmitters. It is also called a “tickler oscillator” because its distinguishing feature is that the feedback signal is magnetically coupled into the tank inductor "tickler coil" in the output circuit.

Q8 What is the main oscillating component in a Pierce oscillator?

Crystal

Q8 How would you identify the following oscillators?

- Hartley oscillator has feedback from tapped inductors. (*H*)artley = *Henries* = *inductors*
- Colpitts oscillator has feedback from tapped capacitors. (*C*)olpitts = *capacitance*
- Clapp oscillator has feedback from tapped capacitors but in parallel with series tuned circuit.
- The Armstrong oscillator has feedback from a tapped transformer. *Strong arm to lift the transformer.*
- Pierce oscillator has a crystal.

Q9 How would you make a PLL oscillator into a frequency synthesiser?

By programming changes the feedback from the VCO to the phase comparator circuit.

