

**Lesson 13 – Answers**

Q1 What is a modulator?

**A modulator superimposes a low-frequency (information) signal onto a high-frequency (carrier) signal for the purpose of transmission.**

Q2 What is high level and low-level modulation?

**High level modulation is where the modulator is connected to the power amplifier.**

**Low level modulation is where the modulator is connected a few stages prior to the power amplifier.**

Q3 Draw and label a block diagram of a simple CW transmitter.

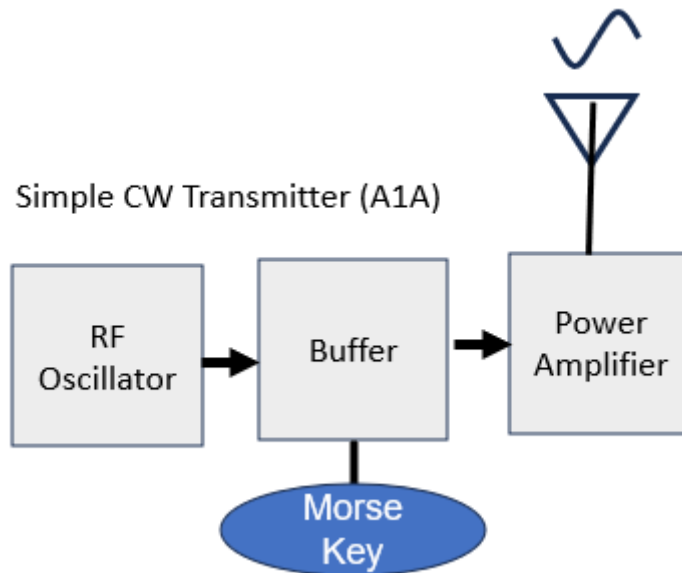

Q4 What are key clicks and chirps.

**Two issues with CW transmitters are Key clicks and chirps.**

- **Key Clicks.** CW transmitted with poor waveform shaping causes interference. This is heard as clicks and thumps by other CW operators on nearby frequencies. Key Clicks can be reduced by using a Key Click filter to shape the transients between transmission bursts of morse code. This filter can be a simple RC network to shape the attack and decay times of the transmissions.

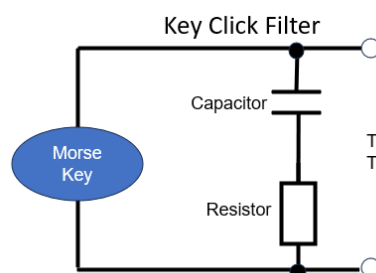

- **Chirps. Oscillator stability is essential for a clean transmission. Any variation in the frequency as the transmitter is keyed is called a chirp. This is an unpleasant signal to receive.**

Q5 How are the key clicks eliminated?

**Key click filter above.**

Q6 What are the five types of modulation used by amateur operators?

**AM, FSK, FM, SSB and CW**

Q7 Draw and label a block diagram of a simple AM transmitter.

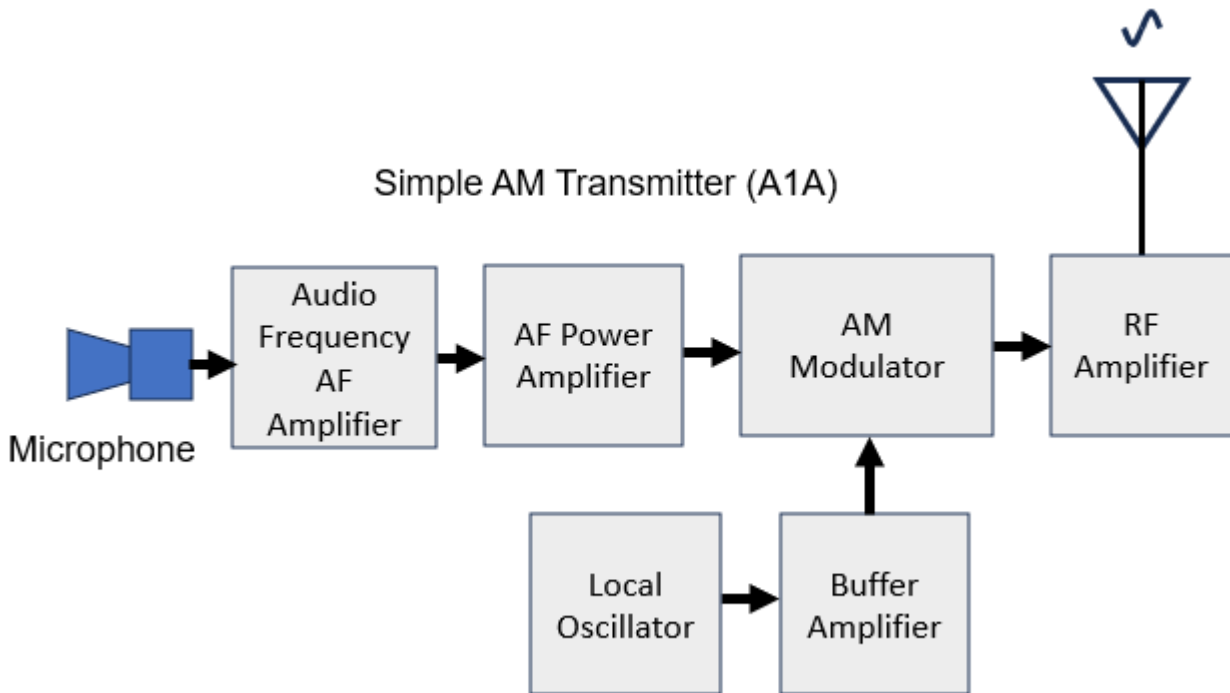

Q8 Draw an AM carrier wave modulated to 100%.

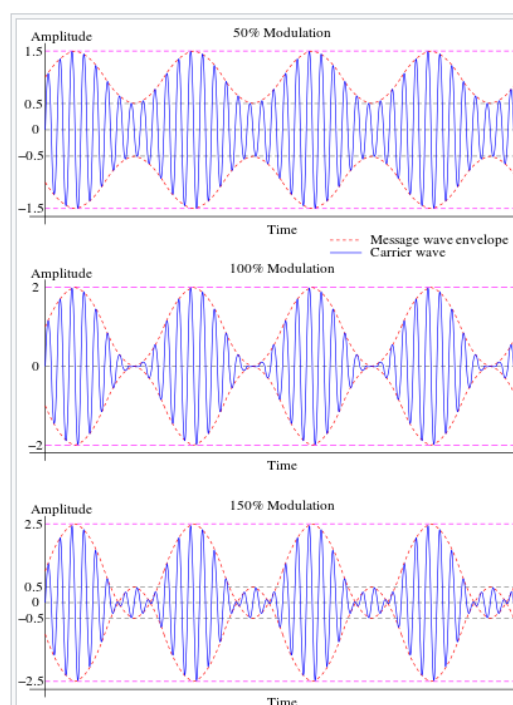

- Q9 Draw an AM carrier wave modulated to 50%.
- Q10 An AM signal has an amplitude of 7 V peak and the modulation signal had a peak of 3.3 V. What is the AM modulation index?  
**47%**
- Q11 Draw and label a block diagram of a simple SSB transmitter.

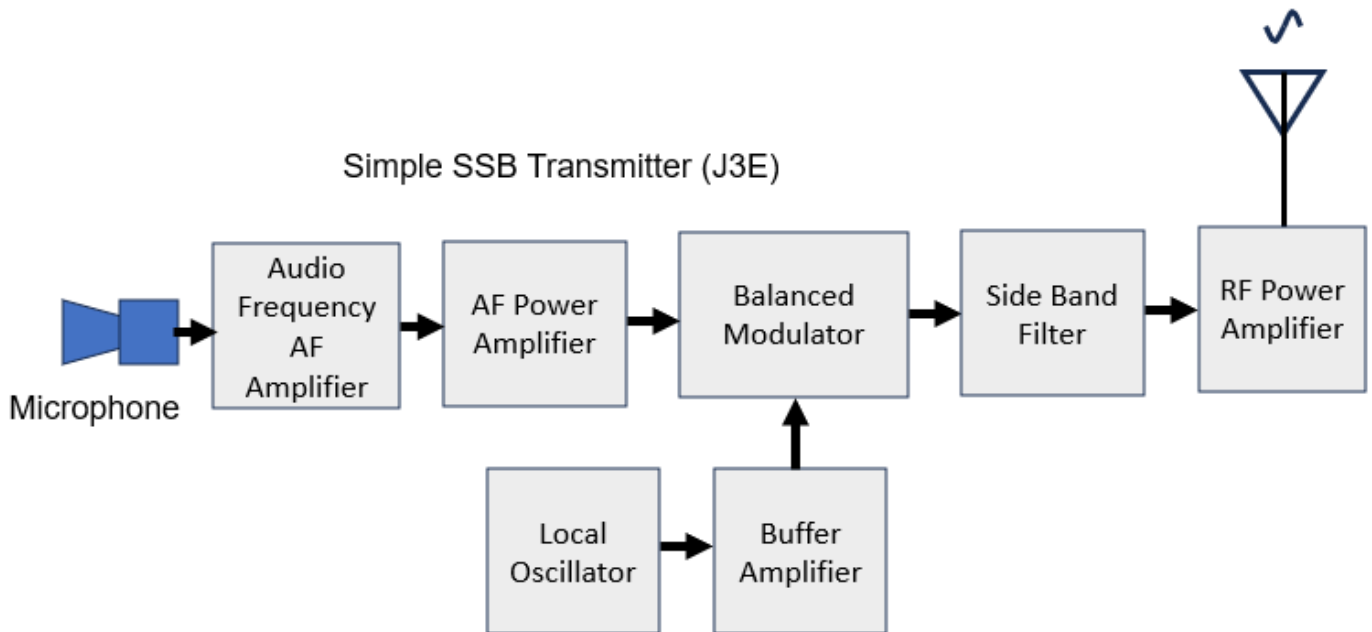

- Q12 What is a balanced modulator and why is it used?  
**A balanced modulator adds the message to the carrier so that only the sideband signals come through the output modulator. This creates a balanced signal, as there is less noise because the carrier signal has been removed.**
- Q13 What is the amateur operator convention for when to use USB and LSB?  
**The upper side band (USB) or lower side band (LSB) can be selected. Amateur radio convention is that for frequencies greater than 10 MHz USB is used. For frequencies below 10 MHz, LSB is used.**
- Q14 Draw and label a block diagram of a simple FM transmitter.

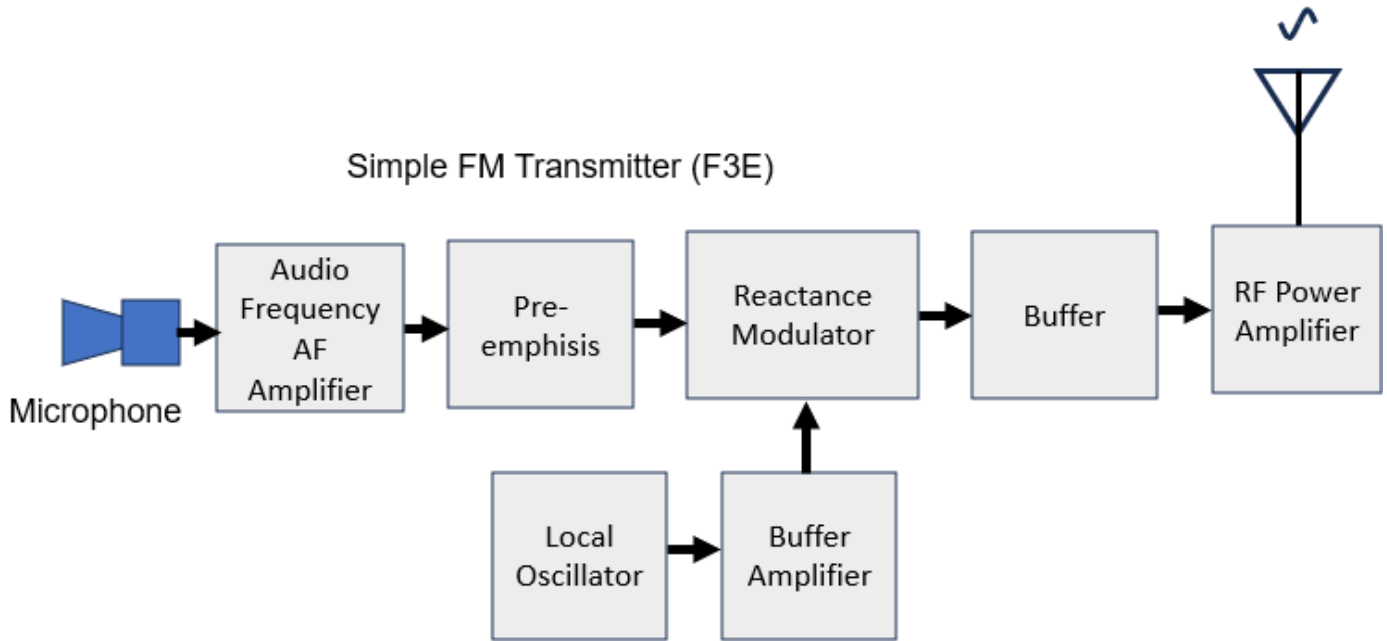

Q15 A FM signal with a carrier at 2KHz has a signal deviating the carrier by +/- 100 KHz. What is the frequency modulation index?

**50**

Q16 What bandwidth is occupied by a FM signal if a 2 KHz tone deviates the carrier by 100KHz?

**220 KHz**

Q17 What is a VFO?

**Variable-frequency oscillator (VFO) - A VFO is an oscillator whose frequency can be tuned over some range**

Q18 Draw a block diagram of a PLL and explain its operation.

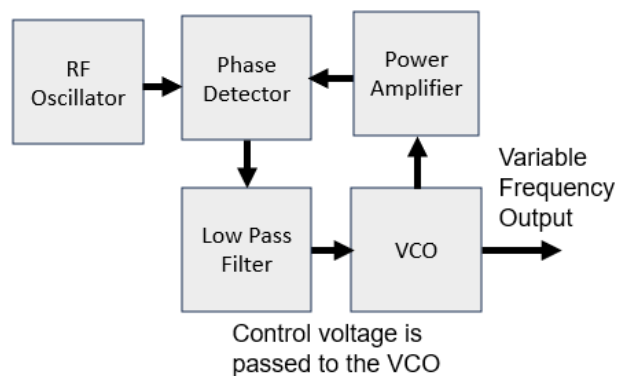

Q19 What is DDS?

**Direct Digital Synthesis (DDS) - DDS is a method to generate a sine wave using digital techniques. The analogue signals are synthesized from values stored and used to recreate the signal.**

Q20 Why would a designer use a frequency doubler or tripler?

**Frequency synthesizers can output a clean stable signal up through UHF but it was not practical to operate the oscillator at the final output frequency. Multiplying the frequency is more common up to the final required frequency.**

Q21 Explain the measurement of peak envelope power.

**Peak envelope power (PEP) is the average power over a single radio cycle.**

Q22 What is a linear amplifier and why are they used?

**Linearity refers to the ability of the amplifier to produce signals that are accurate copies of the input and at increased power levels. No amplifier can provide perfect linearity however, the amplifying devices follow nonlinear function and rely on circuitry techniques to reduce those effects.**

Q23 Where would an amateur operator find the emission modes for amateur use?

**Schedule 1 of the Radiocommunications Licence Conditions (Amateur Licence) Determination 2015 (LCD).**

Q24 What is the ALC?

**An ALC circuit controls the signal strength at the input to the power amplifier in a ham radio transmitter. The ALC keeps the power amplifier input at the designed range for linear operation. Overdriving the ALC circuit can distort the signal and cause interference.**

Q25 What duty cycle does RTTY transmission occupy?

**100%**

