

**Lesson 9 – Answers**

Q1 Draw NPN and a PNP transistor naming the terminals.

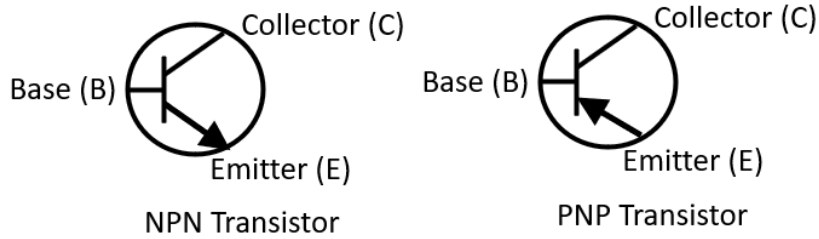

Q2 Complete the table below.

	Symbol	Explanation
Collector current	$I_C$	Current through the collector
Base Current	$I_B$	Current through the base
Emitter current	$I_E$	Current through the emitter
Turn on voltage	$V_{BE}$	$V_{BE(sat)}$ is the required base voltage that must be present in order to forward-bias the transistor's base/emitter junction (i.e., to turn the transistor on). Generally speaking, this value is between .6 to .7 volts for a general-purpose transistor.

Q3 Draw the following diagrams for either NPN or PNP transistors. Include the characteristics of each configuration.

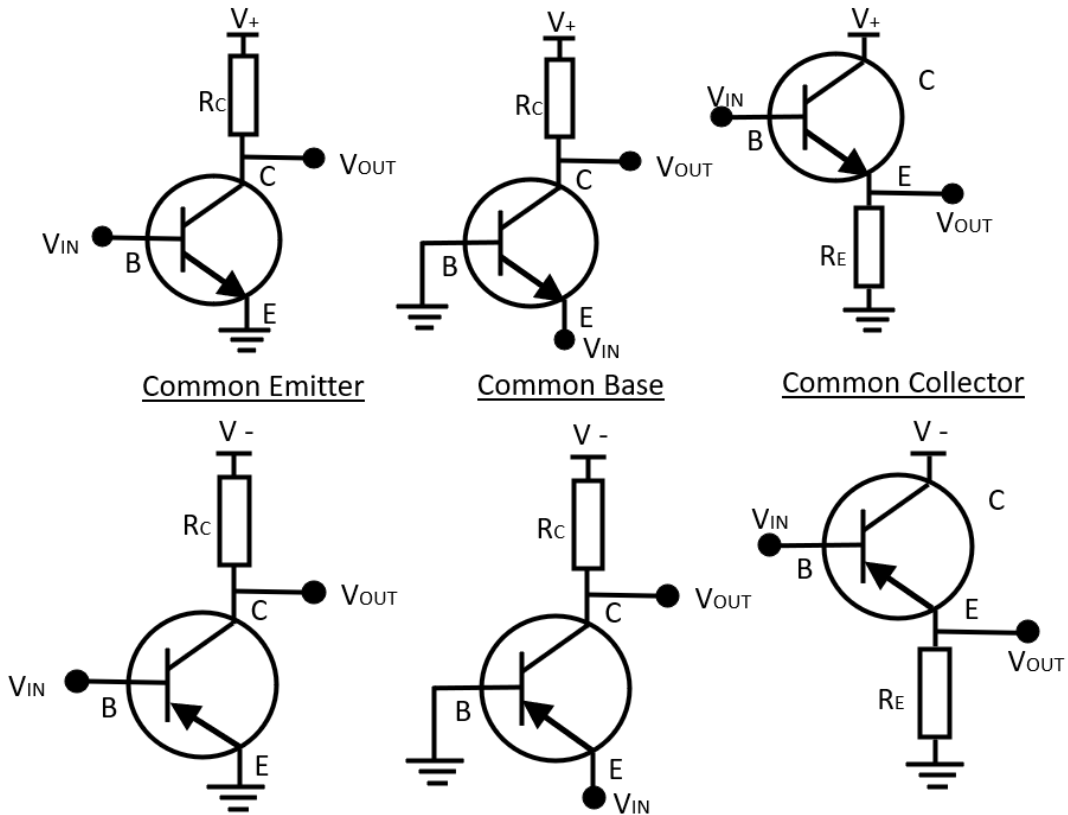

Configuration	Input Impedance	Output impedance	Gain	Orientation
Common Emitter	Medium	High	High	Inverting
Common Base	Low	High	Unity	Non - inverting
Common Collector	High	Low	High	Non - inverting

Q4 What is a Darlington pair?

A Darlington pair is a circuit consisting of two bipolar transistors with the emitter of one transistor connected to the base of the other. The collectors of both transistors are connected together and this gives a much higher current gain than each transistor taken separately. This is usually sold as a single transistor package.

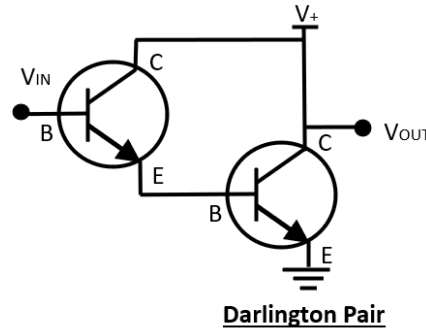

Q 5 Describe the following classes (A, B, AB and C) of amplifiers

**Class A** - Class A amps are simple devices using one transistor and transmit over the full 360 degrees of the signal. Class A efficiency is only 30%.

**Class B** – Class B uses two transistors, each operating in only 180 degrees of the signal. This provides a greater amplification and clearer signal. The downside is that each transistor requires 0.7 V to turn on and this can cause distortion. This area is termed the ‘Dead Zone’.

**Class AB** – Diodes are fitted to the circuit to bias the transistors across the dead zone and minimise distortion.

**Class C** – Class C power amplifier is where the transistor conducts for less than one half of the input cycle. The reduced conduction angle improves efficiency but causes distortion. Theoretical maximum efficiency of a Class C amplifier is around 90%.

Q 6 What is a diode and draw the symbol?

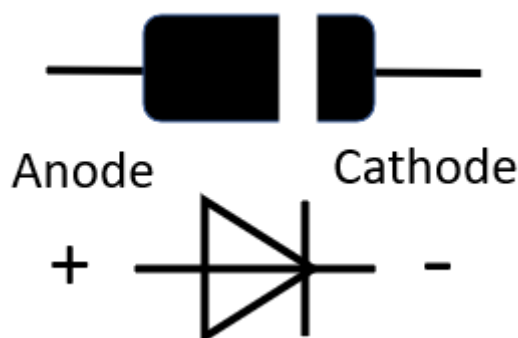

Q7 What is a Zener diode and how does it work?

A Zener diode is a special type of diode designed to reliably allow current to flow "backwards" (inverted polarity) when a certain set reverse voltage, known as the Zener voltage, is reached.

Q8 What is the forward bias of a diode?

This is the point at which the diode will start conducting in the forward direction.

Q9 Draw a diode symbol and indicate the direction of current flow for a normal diode.

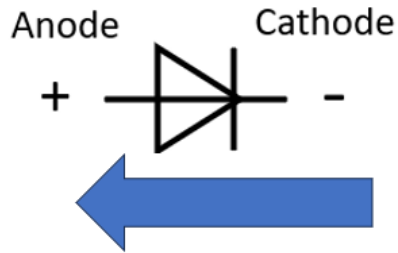

Q10 What is a Schottky diode and why are they used?

**The Schottky diode is formed by the junction of a semiconductor with a metal. It has a low forward voltage drop and a very fast switching action.**

**Diodes have a forward voltage drop of about 0.7 V and germanium diodes 0.3 V, Schottky diodes' voltage drop at forward biases of around 1 mA is in the range of 0.15 V to 0.46 V. This makes them useful in voltage clamping applications and prevention of transistor saturation.**

